

A-A (4:1)

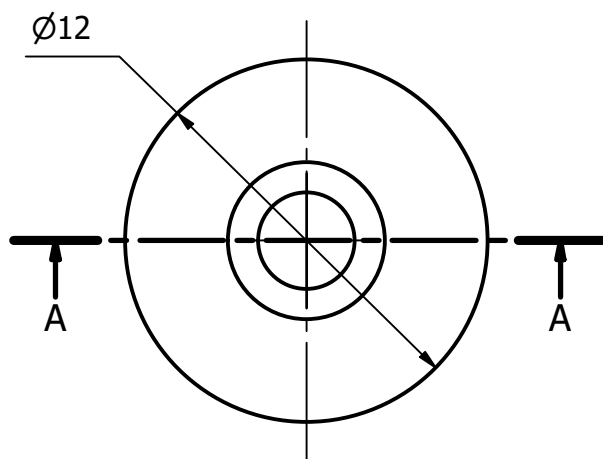
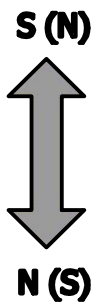
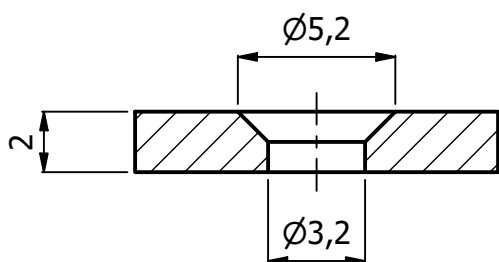

N.B: per il fissaggio si consiglia l'uso di viti a testa svasata con diametro nominale inferiore all' M3.

Rev.	Descrizione modifiche	Data	Firma

Disegnato M.D.	Data 11/06/2024	Materiale Neodimio	Trattamento Nichelato	Tolleranza +/- 0.1	Unità mm
-------------------	--------------------	-----------------------	--------------------------	-----------------------	-------------

**ITALFIT magneti**

Via Comelli, 39  
33034 Fagagna (Ud)  
Tel 0432/801675 Fax 0432/810197  
P.IVA e C.F. 02610340305

Descrizione

Magnete con foro svasato - magnetizzazione assiale (N+S)

Codice

NS01.35NI00.1223

Scala

4 : 1

Formato

A4